

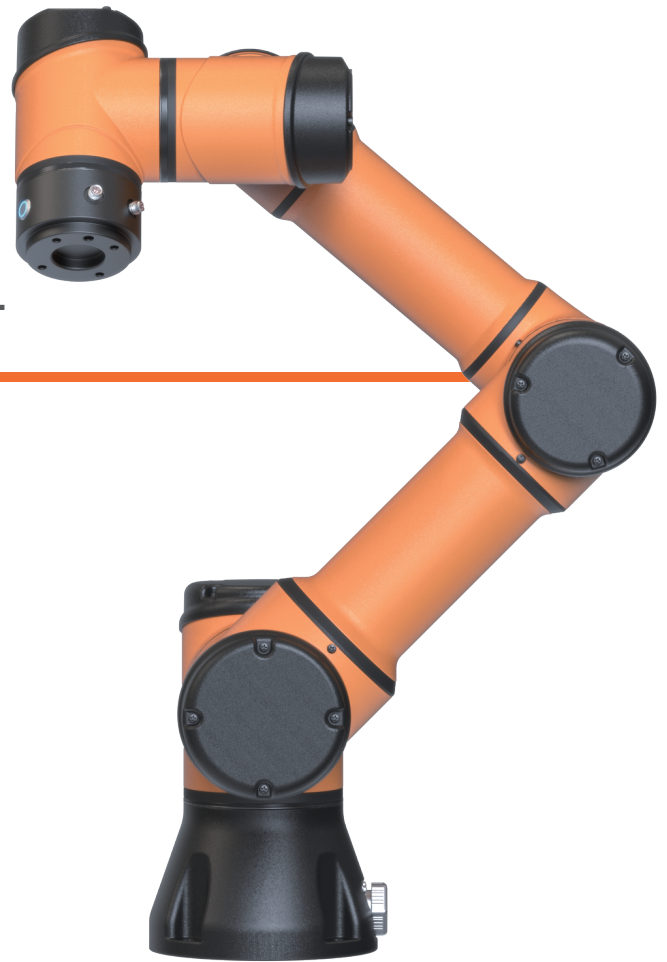

AUBO-i3

i SERIES

COLLABORATIVE ROBOT



 **3KG**
Payload

 **16KG**
Weight

 **±0.02mm**
Repeatability

 **625mm**
Reach

- ✓ AUBO-i3, only weights 16kg
- ✓ Payload capacity is 3kg, with a maximum working radius of 625mm
- ✓ Compact and lightweight, it has a small footprint

Application Fields

3C electronics, automotive, new energy, semiconductors, mechanical processing, hardware home appliances, kitchen and bathroom sanitary ware, medical health, scientific research and education, catering, new retail, daily chemicals, logistics.

Product Advantages

- 01 More Accurate Positioning** The repeatability and power-on positioning accuracy have been further improved, the maximum collision force value has been reduced, and millisecond-level system response speed ensures accurate positioning, resulting in a smoother operation trajectory.
- 02 Faster Speed** Working speed has been increased by 10%-20%. The 6-axis robotic arm operates efficiently, which significantly improves work efficiency.
- 03 Stronger Functionality** An open system platform with integrated 485 communication at the end of the arm has been adopted, and functions such as end-of-arm tool drag-and-drop teaching are added. It supports high-current power supply and can directly establish communication with a wider variety of end effectors, vision systems, mobile and other peripheral equipment, making the system more flexible and convenient.
- Superior Safety** The product has passed multiple professional certifications, is stable and reliable, with improved collision detection sensitivity, and does not require safety barriers, making human-robot collaboration safer.



-  High Performance
-  High Precision
-  Rapid Response
-  Safe and Stable
-  Modular Design
-  Flexible Production
-  Fine Workmanship
-  High Protection Level
-  Compact and Portable
-  Others

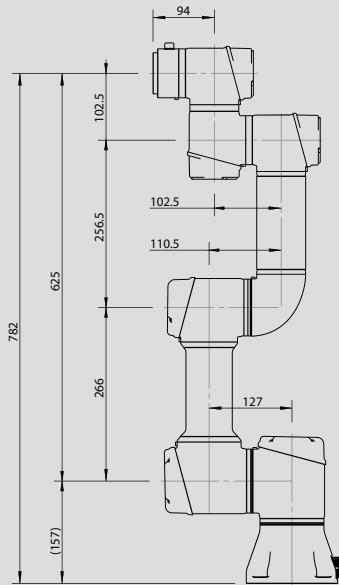

AUBO-i3 Dimensions

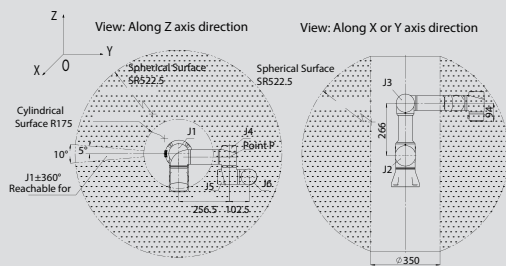

AUBO-i3 Moving Range of Point P

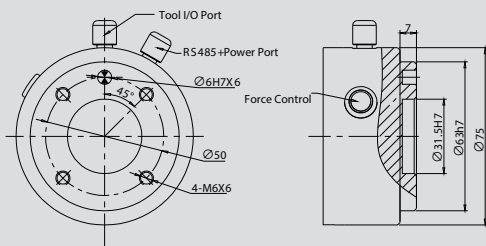

AUBO-i3 Tool End Flange

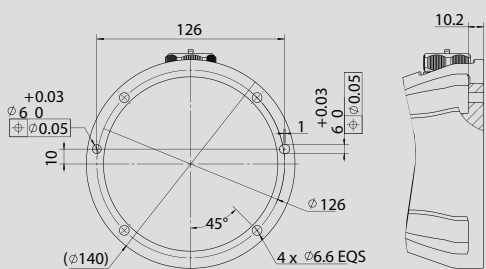

AUBO-i3 Top View of Base

Robot

Degrees of Freedom	6
Reach (mm)	625
Payload (kg)	3
Weight (kg)	16
Mounting Surface Diameter (mm)	Ø140
Repeatability (mm)	±0.02
Linear Velocity (m/s)	≤2.5
Average Power(W)	150
Peak Power (W)	1000
Ambient Temperature (°C)	0-50
Ambient Humidity	90% RH (Non-condensing)
Installation Orientation	Any ceiling, Floor, Wall
IP Classification	IP54
ISO 14644-1 Cleanliness Class	5

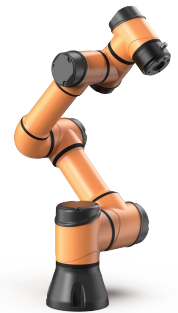

Axis Movement

	Working Range (°)	Maximum Speed (°/s)
joint 1	±360	237
joint 2	±360	237
joint 3	±156	237
joint 4	±360	237
joint 5	±360	237
joint 6	±360	237

*Each joint has the ability of ±360°, but limited by the application scenario, part of the joints may not be reached.

Control Box

Model	AUBO-CB-M
Size (L*W*H)	380mm*350mm*265mm
Weight	15 kg
Cable Connecting Robot	5 m (customizable, up to 8m)
Cable Connecting Pendant	4m
Cable Connecting Power	5m
Communication	Ethernet, ModBus-RTU/TCP, Profinet (optional)
Interface	SDK(support C/C++/C#/Lua/Python), support ROS, API
Power Supply	100-240VAC,50-60Hz
IP Classification	IP43



Control Box I/O, Tool I/O

	Control Box	Tool
I/O Port	Digital In	16 (general) /16 (safe)
	Digital Out	16 (general) /16 (safe)
	Analog In	4
	Analog Out	4
I/O Power	Output Voltage	24V
	Output Current	3A max

Teach Pendant

Model	AUBO-TP
Dimensions	322*236*45.2mm (Excluding E-Stop Button)
Weight	2.56kg (Including Cable)
IP Classification	IP43
Colors	Orange + black



Disclaimer

1. The content of this product catalog is subject to change without prior notice.
 2. This product catalog is an original work of our company and all copyrights belong to us. Please cite the source when reprinting or quoting content from this catalog. Unauthorized reproduction is prohibited and will be considered an infringement, for which legal liability will be pursued according to law.